

Assessment Portfolio 2

Electrolyser and Fuel Cell Experiments
and 3D-Printed Fixture Design for a Hydrogen-Powered Boat

Course: Minor Offshore Renewable Energy (ORE)

Course Code: MI00033

Student Name: Chenjie Cao

Student ID: 105957

HZ University of Applied Sciences

Date: June 21, 2026

Table of Contents

1. Introduction	2
2. Hydrogen Experiments	2
2.1 Electrolyser Experiment.....	2
2.2 Fuel Cell in Series	4
2.3 Fuel Cell in Parallel	6
2.4 Comparison of Series and Parallel Fuel Cell Connections.....	7
3. Mechanical Design Investigation	8
3.1 Design problem	8
3.2 Design requirements	9
3.3 SolidWorks design process	9
3.5 Fastener Selection	13
3.6 Testing, limitations and improvements	15
4. Safety Investigation	16
4.1 Hydrogen Leakage Visualisation	16
4.2 FMEA Analysis	17
5. Integration and Reflection.....	18
6. Conclusion	19
References.....	20
Appendix.....	21
Appendix A — Hydrogen practical assignment results.....	21
Appendix B — SolidWorks design documents.....	21
Appendix C — 3D printed and installed parts	21
Appendix D — FMEA documentation	21

1. Introduction

This portfolio focuses on the development and evaluation of a small hydrogen-powered boat system. The work includes hydrogen experiments, mechanical fixture design, safety investigation and reflection.

The experimental part investigates how hydrogen is produced by an electrolyser and how it is converted back into electrical energy by fuel cells. Measurements such as voltage, current, power, internal resistance and efficiency were used to evaluate the performance of the system.

The design part focuses on the practical installation of hydrogen-related components on the boat. Several 3D-printed fixtures were designed in SolidWorks to support pipes and components, improve stability and make the system easier to assemble and maintain.

The aim of this portfolio is to connect experimental results with practical engineering design. It shows that a hydrogen system must be evaluated not only by its energy performance, but also by its mechanical integration, safety and reliability.

2. Hydrogen Experiments

2.1 Electrolyser Experiment

In the first experiment, measurements were performed on the electrolyser.

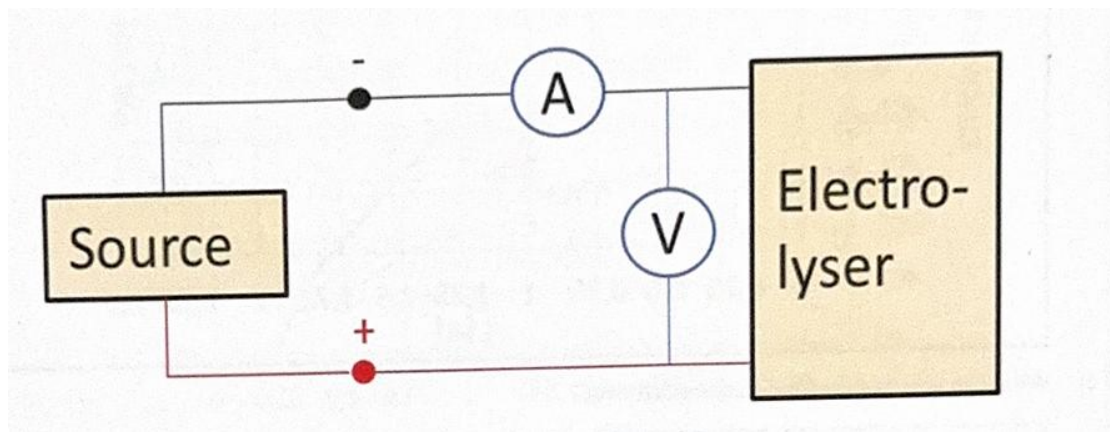

Figure 1. Electrolyser measurement wiring diagram.

Different current settings were used, and the voltage, hydrogen production volume, measurement time, electrical power, electrical energy input, produced hydrogen energy, and efficiency were calculated.

I set	I [A]	U [V]	V [ml]	t [sec]	P _{el} [W]	E _{el} [J]	E _{prod} [J]	η _{el} [%]
0.3	0.366	1.59	3	120	0.582 0.487	69.84 58.38	36	61.7% 21.0%
5 0.6	0.597	1.72	8	120	1.027	123.24	60.96	77.9%
0.9	0.888	1.84	11	120	1.634	196.07	132	67.3%
1.2	1.178	1.97	16	120	2.321	278.48	192	68.9%

↑ WHY NOT STEPS OF? ~~0.5~~ A
0.5 - 1.0 - 1.5 - 2.0
1 2 3 4

VALUES ARE VERY LOW.

EFFICIENCY SHOULD DROP AT HIGHER CURRENTS

Figure 2. Measured values and calculated values of the electrolyser.

The U-I characteristic of the electrolyser showed that the voltage increased as the current increased. This means that the electrolyser required a higher voltage to operate at a higher current. The relationship was approximately linear in the measured range.

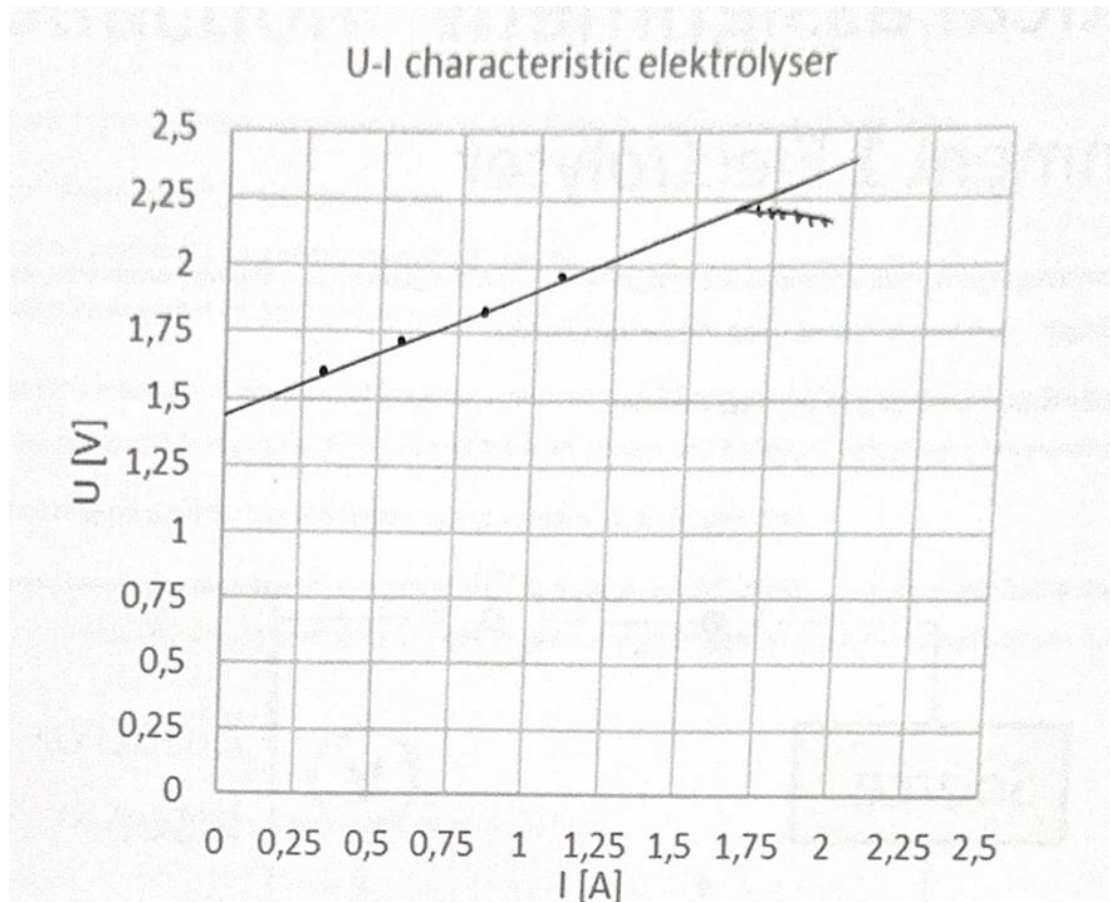

Figure 3. U-I characteristic curve of the electrolyser.

The electrical power consumption also increased with current, because power is

calculated as:

$$P = U \times I$$

The efficiency of the electrolyser was calculated by comparing the produced hydrogen energy with the electrical energy input. The average efficiency was approximately 69%. At higher current levels, the efficiency did not continue to increase. This can be explained by additional losses, such as ohmic losses, heat generation, and gas production losses.

2.2 Fuel Cell in Series

In the second experiment, two fuel cells were connected in series.

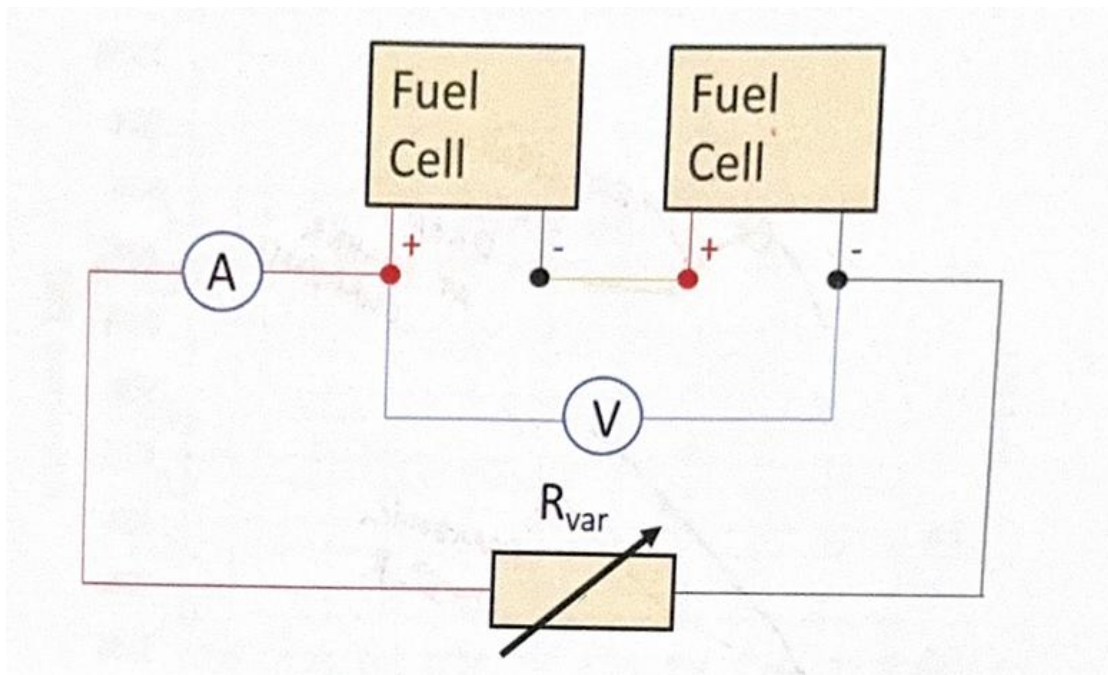

Figure 4. Series fuel cell measurement wiring diagram.

The main advantage of a series connection is that the total voltage increases. The measured open-circuit voltage was approximately 1.85 V, and the short-circuit current was approximately 1.80 A.

I [A]	U [V]	V [ml]	t [sec]	U · I		V · I · t		$\frac{U}{E_{cons}}$	
				P_{fc} [W]	E_{fc} [J]	E_{cons} [J]	η_{fc} [%]		
0	1.85								Open circuit voltage
0.208	1.37	6	120	0.285	34.20	72	47.5%		
0.422	1.35	14	120	0.570	68.36	168	40.7%		
0.52	1.23	20	120	0.640	76.75	240	32.0%		
0.69	1.12	24	120	0.773	92.74	288	32.2%		
1.01	0.91	30	120	0.919	110.29	360	30.6%		
1.30	0.71	40	120	0.923	110.76	480	23.1%		
1.80	0.47			0.846					Short circuit

Figure 5. Measured values and calculated values of the Series fuel cell.

As the current increased, the voltage decreased. This is typical behaviour for a fuel cell. The voltage drop is caused by activation losses, ohmic losses, and concentration losses.

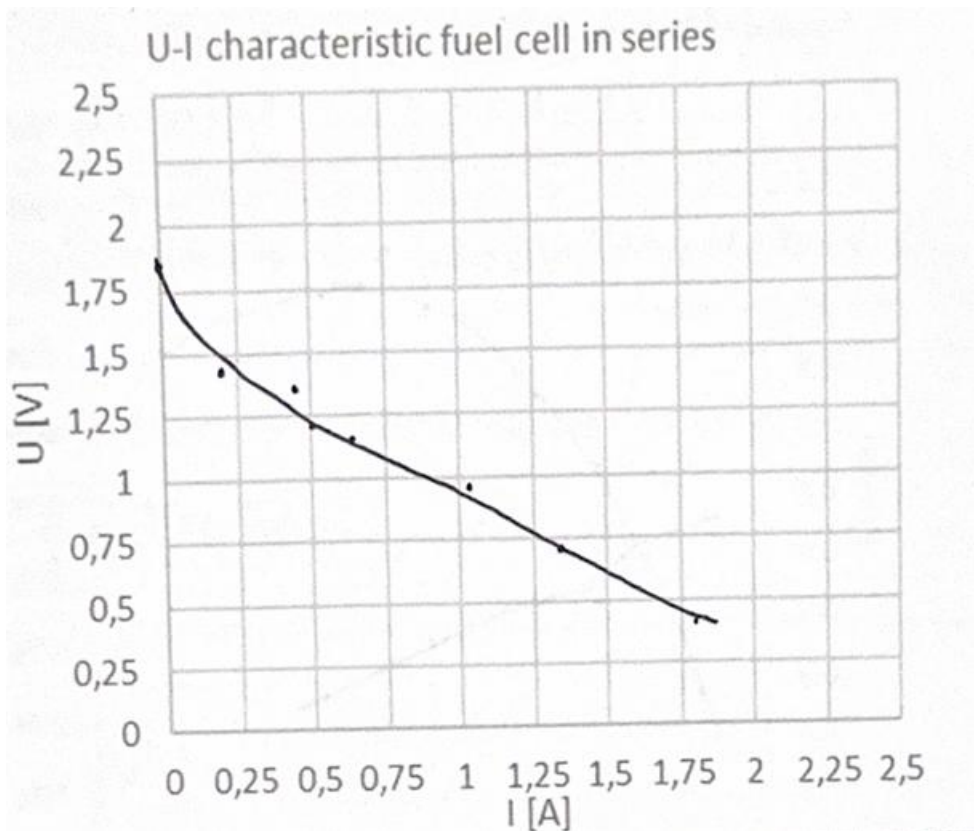

Figure 6. U-I characteristic curve of the fuel cell.

The internal resistance was estimated using the open-circuit voltage and short-circuit current:

$$R_i = U_0 / I_{sc}$$

The calculated internal resistance was approximately 1 Ω . The maximum power point occurred at approximately 1.30 A and 0.71 V, giving a maximum power of about 0.923 W. The average fuel cell efficiency in the series connection was approximately 34.3%. When combined with the electrolyser efficiency, the overall chain efficiency was approximately 23.7%.

2.3 Fuel Cell in Parallel

In the third experiment, the two fuel cells were connected in parallel.

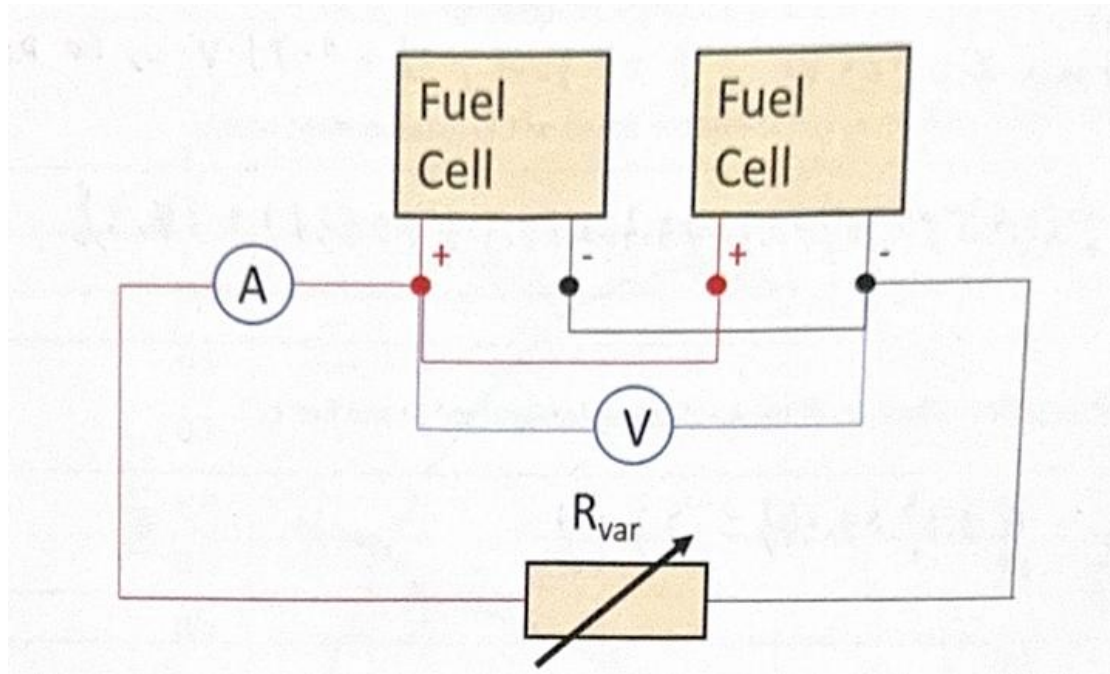

Figure 7. Parallel fuel cell measurement wiring diagram.

In a parallel connection, the voltage remains lower than in a series connection, but the system can provide a higher current capacity and a lower equivalent internal resistance.

I [A]	U [V]	V [ml]	t [sec]	P _{fc} [W]	E _{fc} [J]	E _{cons} [J]	η _{fc} [%]	
0	0.88							Open-circuit voltage
0.207	0.76	2	90	0.157	14.13	24	58.9%	
0.396	0.70	4	90	0.277	24.95	48	52.0%	
0.597	0.66	7	90	0.394	35.46	84	42.2%	
0.990	0.51	13	90	0.505	45.44	156	29.1%	
1.197	0.58	15	90	0.694	62.48	180	34.7%	EFFICIENCY SHOULD DECREASES
1.310	0.57	16	90	0.747	67.20	192	35.0%	
1.844	0.48			0.885				Short-circuit

Figure 8. Measured values and calculated values of the Parallel fuel cell.

The measured open-circuit voltage was approximately 0.88 V, and the short-circuit current was approximately 1.844 A. The calculated internal resistance was approximately 0.48 Ω, which is lower than the internal resistance of the series-connected fuel cell setup.

The average efficiency of the parallel-connected fuel cell was approximately 42.0%. The chain efficiency of the electrolyser combined with the parallel fuel cell was approximately 29.0%. Compared with the series connection, the parallel connection had a lower voltage but better efficiency in this experiment.

2.4 Comparison of Series and Parallel Fuel Cell Connections

The series connection produced a higher voltage, which is useful when the load requires a higher operating voltage. However, it also had a higher internal resistance. The parallel connection produced a lower voltage but had a lower internal resistance and better average efficiency in the measurements.

This comparison shows that the choice between series and parallel connection depends on the application. If higher voltage is required, a series connection is more suitable. If lower voltage and higher current capability are required, a parallel connection can be more suitable.

3. Mechanical Design Investigation

3.1 Design problem

The second part of this portfolio focuses on the mechanical design of fixtures for a hydrogen-powered boat. In a hydrogen system, not only the electrical and chemical performance is important, but also the physical installation of the components. Pipes, reducers, regulators and other small components must be fixed securely so that they do not move during operation.

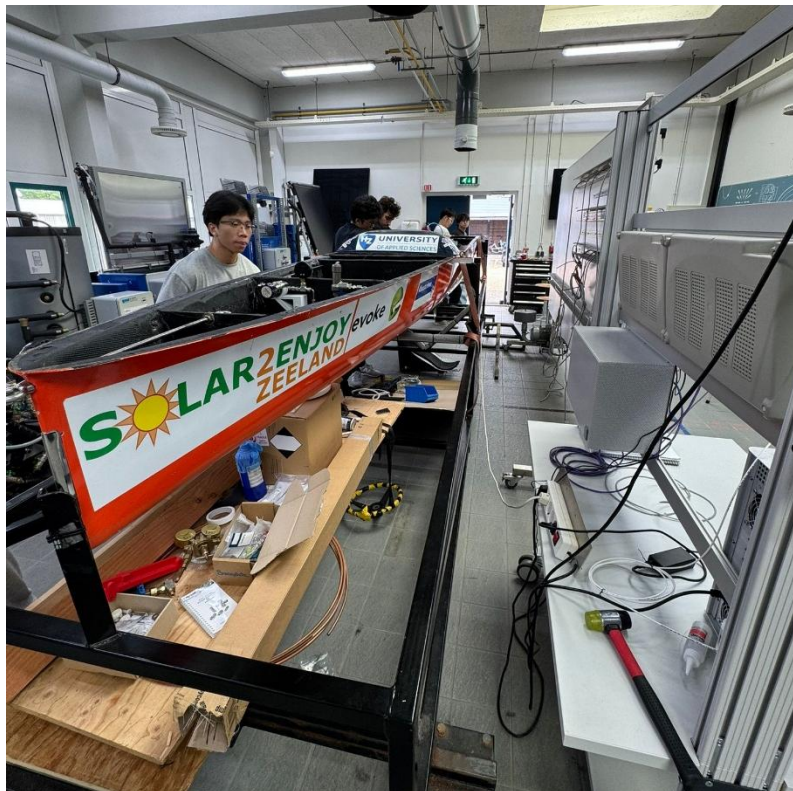

Figure 9. Overview of the hydrogen-powered boat

The main design problem was to create suitable holders and clamps for hydrogen-related components on the boat. Since the boat is a small prototype, the available space is limited. The components also need to be accessible for inspection, maintenance and replacement. In addition, movement and vibration can occur when the boat is transported or operated. If pipes or components are not fixed properly, this could lead to unwanted movement, bending stress on connections, or damage to the system.

At the beginning, the main uncertainty was how to design a clamp that could securely hold the hydrogen-related pipe or component while still being easy to 3D print and assemble. Therefore, I compared a split clamp structure with a one-piece holder and finally selected the split design because it allows easier installation and removal.

The designed parts include a pipe clamp base, a lower pipe clamp, a top pipe clamp, a full pipe clamp assembly and a reducer holder. These parts were designed in SolidWorks and are intended for prototype use on the hydrogen-powered boat.

3.2 Design requirements

Before starting the SolidWorks modelling process, several design requirements were defined. These requirements were used as criteria to evaluate whether the final fixture design was suitable for the hydrogen-powered boat.

Table 1. Summary of electrolyser experiment results.

Requirement	Meaning
Secure fixation	The fixture must hold the pipe or component without unwanted movement.
Easy assembly	The part should be easy to install, remove and adjust.
3D printing suitability	The geometry should be simple and printable with limited support.
Practical mounting	Screw holes and contact surfaces should be accessible.
Lightweight design	The fixture should provide support without unnecessary weight.
Maintainability	The design should allow later adjustment or replacement.

3.3 SolidWorks design process

The design process started by identifying the components that needed to be fixed on the hydrogen-powered boat. The pipe and reducer were treated as the main components requiring support. After this, the fixture design was divided into separate parts so that each part had a clear function.

The pipe clamp was modelled as a multi-part assembly. The base was designed first because it defines the mounting position of the clamp on the boat structure. After that, the lower pipe clamp was created to support the pipe from below. The top pipe clamp was then designed to close the clamp from above and secure the pipe in position. And what is also important is considering how to connect those parts between each other as an assembly.

In SolidWorks, the modelling process began with simple 2D sketches. The main bodies were created using extruded features. The pipe contact area was shaped according to the old document sketches' pipe diameter. Screw holes were added to connect the

upper and lower clamp parts. Fillets were added to remove sharp edges and reduce stress concentration.

After the individual parts were completed, they were combined in a SolidWorks assembly. The assembly was used to check the alignment between the base, lower clamp and top clamp. It also made it possible to check whether the screw holes matched and whether the pipe could fit correctly between the clamp parts.

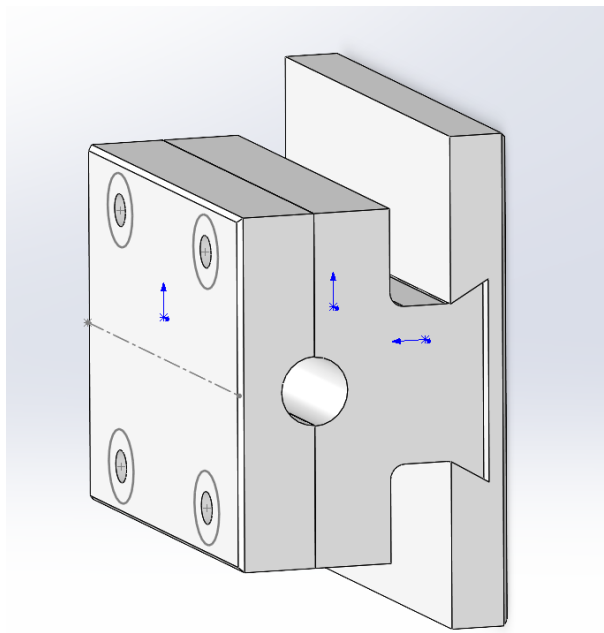

Figure 10. The screenshot of Pipe Clamp Assembly

This step was important because a part may look correct individually but still create problems during assembly. The assembly also helped to visualize how the clamp would work in the real boat system.

The reducer holder was designed as a whole. Its purpose was to support the reducer or regulator component and keep it in a fixed position. The design had to provide enough contact area to stabilize the component while still allowing access for installation and inspection.

When designing the holder, the position of pipe connection also was considered so that the reducer and holder can have a full surface clinging to the board, which is more stable.

During the design process, the main focus was not only on the shape of each part, but also on how the parts would be used. This included checking the direction of assembly, screw accessibility, possible 3D printing orientation and the available space around the hydrogen system.

3.4 Designed components

Several components were designed for the mechanical fixture system.

The pipe clamp base provides the main mounting platform. It connects the clamp to the boat structure and gives the assembly stability. A flat bottom surface was used so that the base can be mounted more easily. The base also provides the dovetail groove for the upper and lower clamp parts to install.

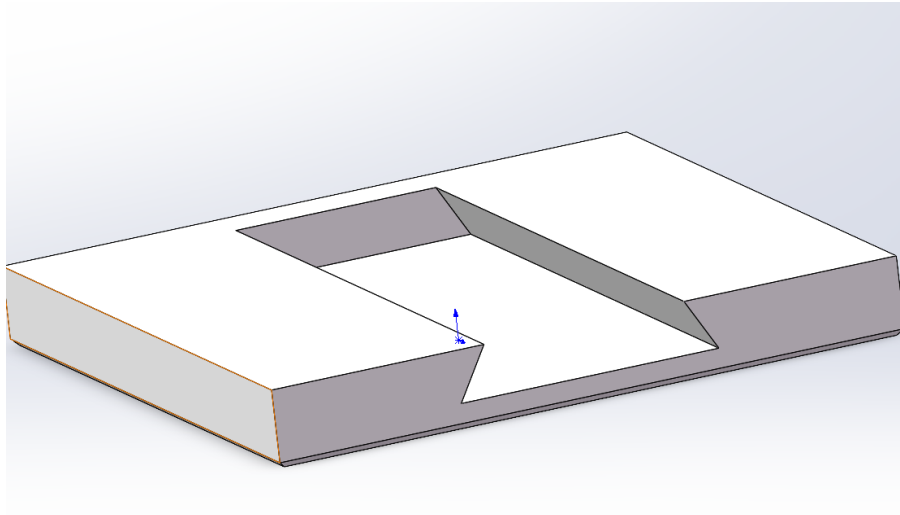

Figure 11. The screenshot of Pipe Clamp Base

The lower pipe clamp supports the pipe from below. It includes a curved contact area so that the pipe can sit in a stable position. This part carries the pipe and helps distribute the contact force instead of concentrating the load at one point. At the same time, fillets were added to reduce sharp edges and improve the printed part quality.

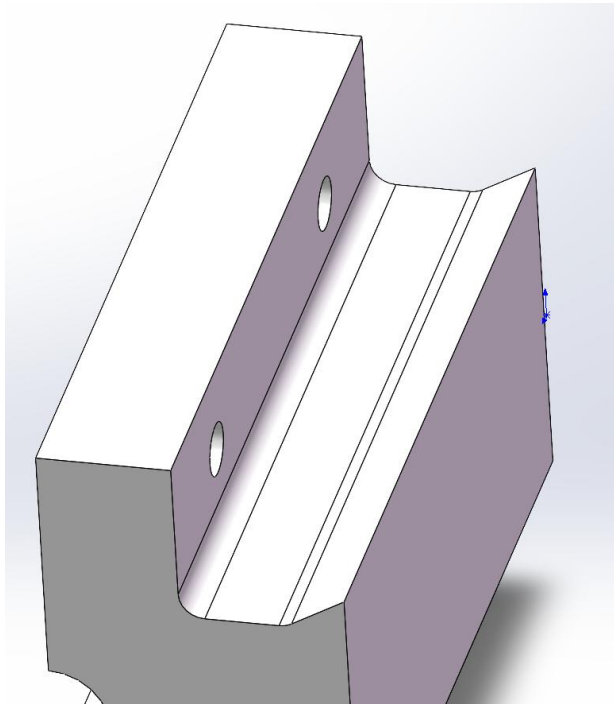

Figure 12. The screenshot of fillets added in Lower Pipe Clamp

The top pipe clamp fixes the pipe from above. Together with the lower pipe clamp, it forms a split clamp structure. This design choice improves assembly because the pipe does not need to be pushed through a closed hole. Instead, the pipe can be placed in position first and then secured by the top clamp. Connecting those two parts, M3x22mm Cylinder Head Bolt, Flat Washer and Nylon Locking Nut were used.

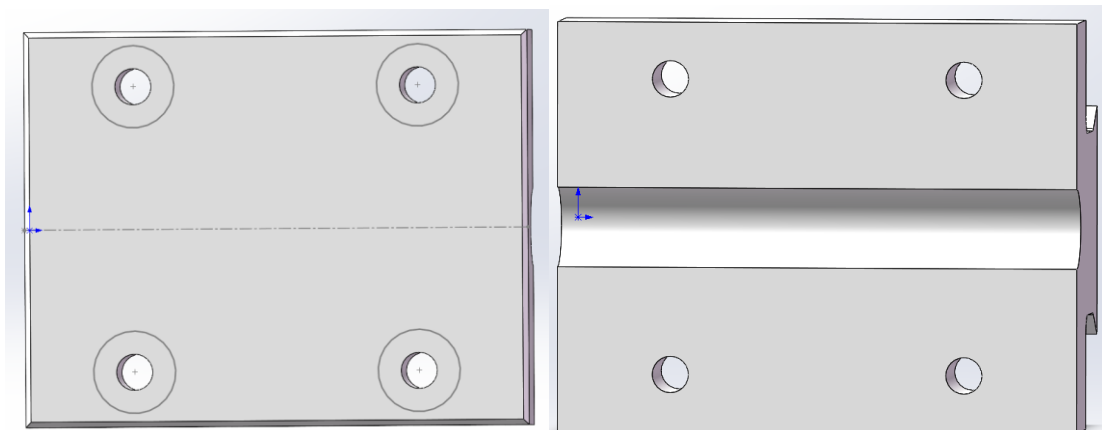

Figure 13. The screenshot of hole on Pipe Clamp

The reducer holder was designed to support the reducer and keep it in a fixed position. This is important because unsupported components can move during transport or operation, which may create stress on connected pipes or fittings. The holder also helps keep the system more organised and easier to inspect.

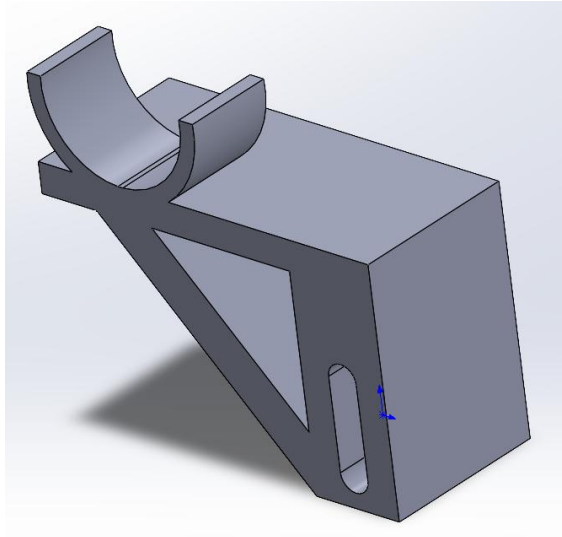

Figure 14. The screenshot of reducer holder

Overall, the designed components form a simple mechanical support system for the hydrogen-powered boat. The clamp system focuses on pipe fixation, while the reducer holder focuses on stabilising another hydrogen-related component. Together, these parts improve the mechanical integration, accessibility and maintainability of the prototype hydrogen system.

3.5 Fastener Selection

The pipe clamp assembly uses M3x22 mm cylinder head bolts, M3 flat washers and M3 nylon locking nuts. This combination was selected to provide a stable and corrosion-resistant connection for the 3D-printed clamp system.

The cylinder head bolt provides enough length to connect the clamp parts and can be tightened with an internal hex key, which is practical in the limited space of the boat. The flat washer distributes the clamping force over the printed surface and reduces local stress around the screw hole. The nylon locking nut helps prevent loosening caused by vibration during transport or operation.



Figure 15. Selected M3 A4 stainless-steel fasteners used for the pipe clamp assembly.

A4 stainless steel was selected because the boat operates in a wet and possibly marine environment. Compared with ordinary steel, A4 stainless steel gives better corrosion resistance and is more suitable for parts exposed to moisture. Therefore, the selected fasteners support both the mechanical stability and the environmental durability of the fixture design.

3.6 3D printing considerations

The fixture parts were designed with 3D printing in mind. Since the project is a prototype, 3D printing is a suitable manufacturing method because it is fast, flexible and cost-effective. It also allows the design to be modified easily after testing.

One important consideration was print orientation. The parts should be placed on the print bed in a way that reduces the need for support material. Flat surfaces were included where possible to make the parts easier to print. For the clamp parts, the orientation should also consider the direction of the clamping force, because FDM printed parts are usually weaker between layers than along the printed paths.

Another consideration was the use of fillets and rounded edges. Sharp corners can create stress concentration and may also be uncomfortable or unsafe during handling. Rounded edges improve the mechanical behaviour of the part and make the printed component cleaner.

The screw holes also require attention during printing. Hole diameters in 3D printed parts are often slightly smaller than designed because of printer tolerance. Therefore, the holes may need to be slightly oversized or drilled after printing. This should be checked during the first test print.

Material selection is also important. PLA is easy to print and suitable for early prototypes, but it may not be the best material for long-term use because it has limited heat resistance and impact resistance.

When printing several parts at the same time, the parts should be arranged efficiently on the print bed to reduce unnecessary printer movement and printing time.

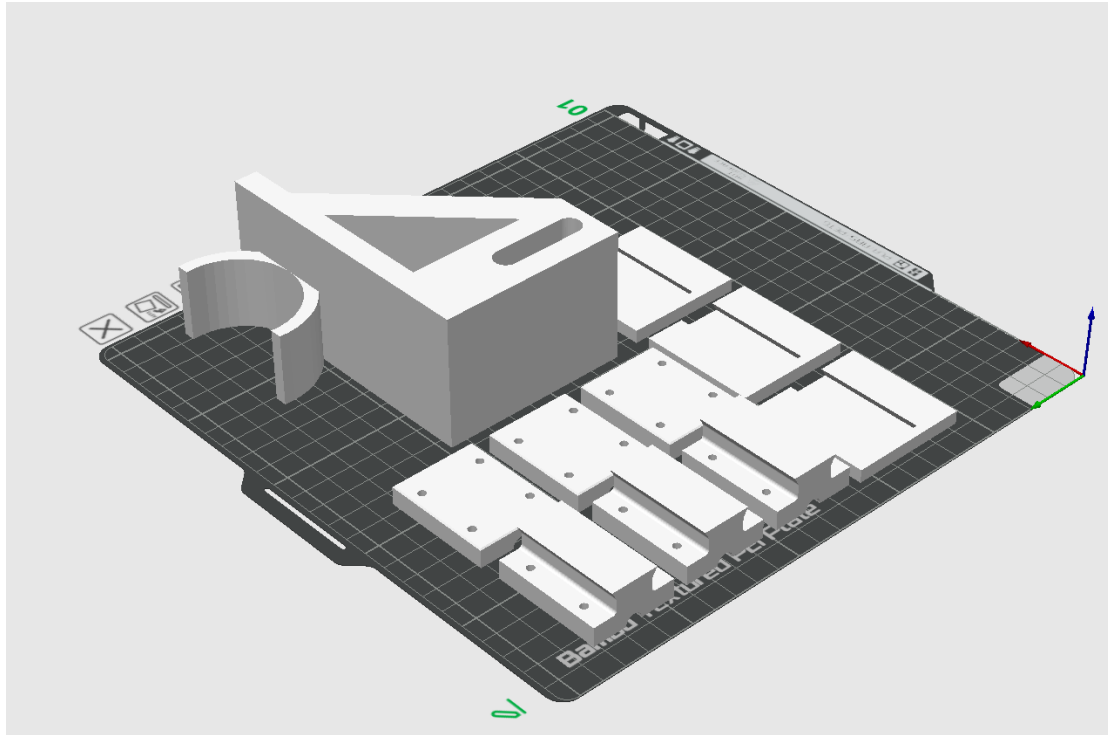

Figure 16. The layout of 3D printing slicer application

3.6 Testing, limitations and improvements

After the design stage, the next step is to test whether the fixtures work correctly in practice. The first test should be a basic fit test. The pipe should fit into the lower clamp without being too loose or too tight. The top clamp should close properly, and the screw holes should align with the base and lower clamp.

The second test should check assembly and disassembly. The clamp should be easy to install without requiring excessive force. The pipe or reducer should also be removable for maintenance. This is especially important because prototype hydrogen systems often need modifications during testing.

The third test should check stability. After the pipe or reducer is fixed, the component should not move significantly under light manual force. If movement is observed, the clamp geometry, screw position or contact area may need to be improved.

The fourth test should check the printed part quality. Possible problems include poor layer adhesion, inaccurate holes, weak thin sections, rough contact surfaces or warping. These issues can affect the final performance of the fixture.

There are also several limitations in the current design. First, the design is intended for prototype use and has not been validated for long-term operation. Second, no detailed stress simulation was performed. Third, the behaviour of the printed material under

vibration, temperature change and repeated assembly was not fully tested. Fourth, the fixture itself does not guarantee hydrogen safety; it only supports the mechanical installation of the system.

Future improvements could include adding rubber inserts to protect the pipe, optimising the wall thickness, improving the screw hole design, reducing material use, and performing a simple stress analysis in SolidWorks Simulation. Another improvement would be to test different 3D printing materials, such as PLA, PETG and nylon, and compare their strength and durability.

Finally, the mechanical design investigation showed that small support components are important in a hydrogen-powered boat. The experiments helped explain how hydrogen is produced and used, while the fixture design showed how hydrogen components can be practically integrated into a physical system.

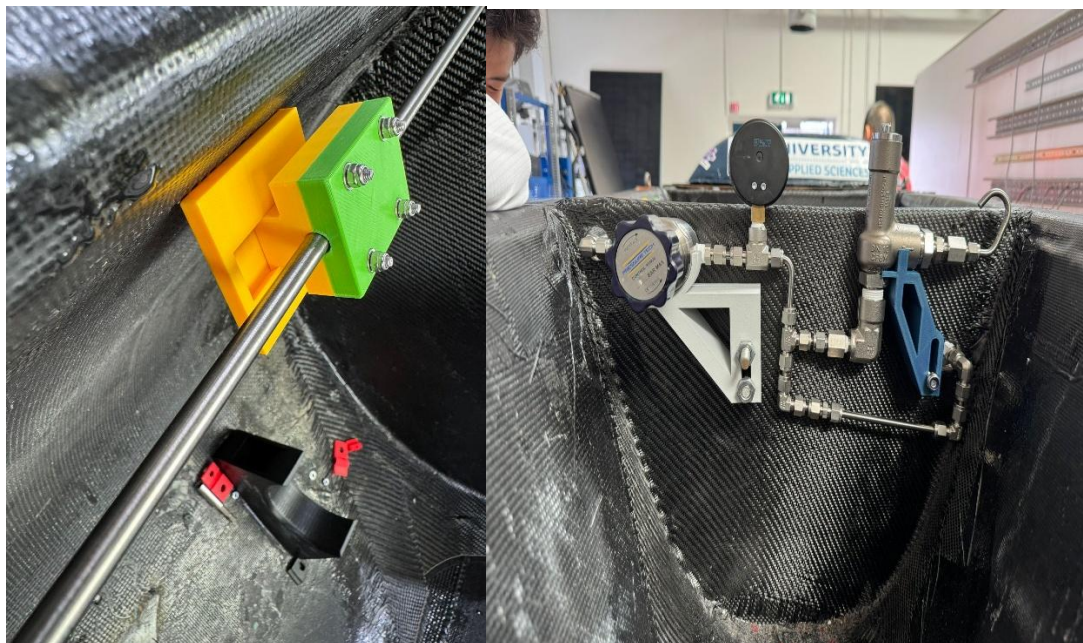

Figure 17. The picture of Pipe Clamp and Reducer Holder installation

4. Safety Investigation

4.1 Hydrogen Leakage Visualisation

A simplified Schlieren imaging experiment was carried out to observe hydrogen leakage behaviour. The aim was not to make an accurate quantitative measurement, but to make the otherwise invisible gas movement easier to observe.

The setup used a point light source, a mirror and a white book cover as a projection screen. When hydrogen was released, a faint visual disturbance could be observed.

The hydrogen plume moved upward quickly, which is consistent with the low density of hydrogen compared with air.

The experiment had several limitations. The alignment of the light source, mirror and screen was difficult to control, and the white book cover was not an ideal screen. Ambient light also reduced the contrast. Future improvements could include using a darker room, a better point light source, a proper matte screen, a camera and a hydrogen sensor.

4.2 FMEA Analysis

A Failure Mode and Effects Analysis was carried out to identify the main risks of the hydrogen-powered boat. The FMEA used severity, occurrence and detectability scores. The risk priority number was calculated as:

$$\text{RPN} = \text{Severity} \times \text{Occurrence} \times \text{Detectability}$$

The highest RPN value was 200. Three failure modes reached this value: hydrogen tube or fitting leak, water ingress into electronics, and corrosion of connectors. These risks are important because they directly affect the safety and reliability of the boat.

Hydrogen leakage can reduce fuel supply and may become dangerous if it occurs near electrical components or ignition sources. Water ingress can cause short circuits or unstable control behaviour. Corrosion of connectors can gradually increase electrical resistance and reduce reliability.

Several medium-level risks were also identified, including fuel cell flooding, insufficient gas supply, 3D-printed holder failure and loose pipes due to vibration. These risks should still be checked during testing, even if their priority is lower than the highest-risk items.

Overall, the FMEA shows that future design improvements should focus on leak prevention, waterproofing of electronics, connector protection, secure pipe routing and regular inspection.

Table 2. Main FMEA risk priorities for the hydrogen-powered boat.

Failure description	Severity	Occurance	Detectability	SxOxD
Water tank leak	8	2	2	32
Water pipe leak	8	2	5	80
Hull damage/crack	8	2	2	32
Hydrogen tube or fitting leak	8	5	5	200
Overpressure or blocked gas line	8	2	5	80
Water ingress into electronics	8	5	5	200
Fuel cell flooding or water contamination	5	5	5	125
Fuel cell drying / insufficient gas supply	5	5	5	125
Electrical short circuit or overheating	8	2	5	80
3D printed holder or clamp failure	5	5	5	125
Loose tank or pipe due to vibration	5	5	5	125
Propeller blockage or motor failure	5	5	2	50
Water pipe clamps are not properly attached	5	5	2	50
Corrosion of connectors	5	8	5	200
Ignition source near hydrogen system	8	2	8	128

5. Integration and Reflection

5.1 Connection between Experiment and Design

The experimental work and the mechanical design work represent two connected parts of the same hydrogen system. The electrolyser and fuel-cell experiments helped me understand how hydrogen is produced and converted back into electrical energy. The measurements showed that voltage, current, internal resistance, power output and efficiency all affect the performance of the system.

However, a hydrogen system is not only an energy conversion system. In a real application, the components also need to be installed safely, fixed securely and maintained easily. This is where the SolidWorks design work becomes important. The pipe clamps, reducer holder and other 3D-printed parts were designed to support the hydrogen-related components on the boat and reduce unwanted movement during operation or transport.

The safety investigation also connects the experimental and design parts. The Schlieren experiment showed that hydrogen leakage can be difficult to observe without suitable detection methods. The FMEA showed that the most important risks are hydrogen leakage, water ingress into electronics and corrosion of connectors. These results show that performance, mechanical integration and safety must be considered together.

5.2 Technical and Design Reflection

Through this portfolio, I developed a more practical understanding of hydrogen technology. Before the project, I mainly understood the basic theory of electrolyzers and fuel cells. After the experiments, I understood more clearly how losses, internal resistance and load conditions influence the real performance of a hydrogen system.

The design part helped me understand how theoretical knowledge is applied in a physical prototype. A component that works in a CAD model still needs to be printable, strong enough, easy to assemble and suitable for the available space. The split clamp design was chosen because it allows the pipe to be installed and removed more easily than a closed one-piece clamp.

I also learned that engineering work involves uncertainty and iteration. Not every requirement was clear at the beginning, so design choices had to be made based on the available information. After printing and installation, the parts still need further testing under more realistic operating conditions. This helped me understand the importance of testing, evaluation and continuous improvement.

5.3 Future Improvements

Several improvements could be made in future work. For the experimental part, more repeated measurements and more load points could be used to improve the reliability of the results. It would also be useful to compare the measured values with theoretical values or manufacturer data.

For the mechanical design part, the next step should focus on long-term reliability. The installed parts should be tested under vibration, transport and repeated assembly conditions. A simple SolidWorks stress analysis could also help identify weak areas in the clamp or holder. In addition, different 3D-printing materials, such as PETG or nylon, could be compared with PLA for better strength and durability.

The boat layout could also be improved further. Future work could optimise pipe routing, cable routing, accessibility for maintenance and the safety distance between hydrogen tubes and electrical components.

6. Conclusion

This portfolio presented the development, testing and evaluation of a small hydrogen-powered boat system. The experimental part showed how hydrogen can be produced by an electrolyzer and converted back into electrical energy by fuel cells. The measured electrolyzer efficiency was approximately 69%, while the fuel cell efficiency was approximately 34.3% in series connection and approximately 42% in parallel connection. These results show that hydrogen systems must be evaluated at system

level, because energy losses occur in both hydrogen production and electricity generation.

The mechanical design part focused on the practical installation of hydrogen-related components on the boat. Several fixtures, including pipe clamps and a reducer holder, were designed in SolidWorks and manufactured by 3D printing. The design process showed that the parts must not only fit the CAD model, but also be printable, easy to assemble, stable and suitable for limited space inside the boat.

The safety investigation showed that hydrogen systems require careful risk assessment. The Schlieren experiment demonstrated that hydrogen leakage can be difficult to detect visually, while the FMEA identified hydrogen tube or fitting leakage, water ingress into electronics and connector corrosion as the highest-priority risks. Therefore, future improvements should focus on leak prevention, waterproofing, connector protection, vibration testing and further optimisation of the system layout.

Overall, this project helped me understand hydrogen engineering as an interdisciplinary task. A successful hydrogen-powered system requires not only fuel-cell performance, but also mechanical support, safe installation, reliable testing and practical maintainability.

References

HZ University of Applied Sciences. (2026). *Practical assignment Hydrogen*. Research group Delta Power.

HZ University of Applied Sciences. (2026). *Schlieren Imaging Experiment*.

International Energy Agency. (2023). *Global Hydrogen Review 2023*. IEA.

U.S. Department of Energy. (n.d.). *Hydrogen and fuel cell technologies office: Fuel cells*. U.S. Department of Energy.

U.S. Department of Energy. (n.d.). *Hydrogen safety*. U.S. Department of Energy.

ISO. (2019). *ISO 14687: Hydrogen fuel quality — Product specification*. International Organization for Standardization.

SolidWorks. (n.d.). *SolidWorks user documentation*. Dassault Systèmes.

Ultimaker. (n.d.). 3D printing materials and design guidelines. Ultimaker.

Stamatis, D. H. (2003). *Failure Mode and Effect Analysis: FMEA from Theory to Execution*. ASQ Quality Press.

NASA. (2008). *Failure Modes and Effects Analysis Guide*. National Aeronautics and

Space Administration.

RVS Paleis. (n.d.). *DIN 912 A4 M3x22 cylinder head bolt*. [URL]

RVS Paleis. (n.d.). *DIN 125A A4 M3 flat washer*. [URL]

RVS Paleis. (n.d.). *DIN 985 A4 M3 nylon locking nut*. [URL]

Appendix

Appendix A — Hydrogen practical assignment results

This appendix includes the completed hydrogen practical assignment sheets.

Appendix B — SolidWorks design documents

The complete SolidWorks design documents are provided as a separate ZIP file.

Appendix C — 3D printed and installed parts

This appendix includes photographs of the manufactured parts after 3D printing and installation on the hydrogen-powered boat.

Appendix D — FMEA documentation

This appendix includes the completed FMEA table for the hydrogen-powered boat.